



# CUTTER STACKER USER MANUAL

CS1000-ZX



User Manual: Cutter Stacker  
Version: 1.0  
Issue Date: May 2016

# Contents

<b>1. Introduction</b> .....	2
1.1. Product description.....	2
1.2 Cutter Stacker main specifications .....	2
<b>2. Basic Safety Precautions</b> .....	3
2.1 Coverage.....	3
2.2 Following these manual’s safety instruction.....	3
2.3 Possible device handling risks.....	3
2.4 Environmental conditions.....	3
2.5 Safety rules and instructions .....	4
2.6 Applied harmonized standards .....	4
<b>3. Box Contents and Overview</b> .....	5
3.1 Unpacking.....	5
3.2 Differences in the printer configuration .....	5
3.3 Overview & Process Description.....	6
3.4 Dimensions .....	7
<b>4. Mounting the cutter stacker on the printer</b> .....	8
<b>5.0 Installing the printer stand (optional)</b> .....	10
<b>6.0 Operating the Cutter Stacker</b> .....	11
6.1 Media loading.....	11
6.2 Stacker settings and adjustments.....	12
6.3 Cut line adjustment.....	14
6.4 Firmware .....	14
6.5 Printer setup .....	14
6.6 Label creation .....	14
6.7 Maintenance.....	15
<b>7.Contact and support</b> .....	15

# 1. Introduction

## 1.1. Product description

The GoDEX CS1000-ZX cutter stacker is a powerful tool to enhance your label production, extremely useful in textile- as well as other applications. After the labels have been printed and cut, the stacker will pile them up for easy and orderly collection. The integrated heavy duty cutter has an adjustable cut line and a life cycle of over 1 million cuts with materials up to 300g/m. The CS1000-ZX can handle materials ranging from satin care labels to thick cardboard hang tags and to avoid static electricity build-up, various anti-static solutions have been applied.

Just like all Godex special solutions the CS1000-ZX Cutter Stacker is of excellent make and it comes with three years' warranty on non-wearing parts. Mounting it is uncomplicated and it is easy adjustable to various label sizes. The Cutter Stacker will pause the printer when full and after removing the label pile one can continue with the print job. The cutter blade and other mechanical parts are easy accessible for servicing.

In spite of its uncompromising quality the CS1000-ZX remains very affordable and combined with our ZX series printer it is definitely the best value print-cut-stack solution on the market today.

This manual will show how to install the cutter stacker on a ZX printer and to set it up for problem-free cutting and stacking of millions of labels. For maintenance instructions we refer to the Cutter Stacker Maintenance Manual which will be made available to authorised dealers.

## 1.2 Cutter Stacker main specifications

<b>Compatible Printers:</b>	<b>ZX1200i</b> (203dpi, 10ips) / <b>ZX1300i</b> (300dpi, 7ips) / <b>ZX1600i</b> (600dpi, 4ips).
<b>Required printer options:</b>	pre-installed modification kit (Art. no. ZX-TEXTILE-MOD).
<b>Suitable materials:</b>	satin, nylon, patch labels, paper, cardboard, hang tags, PP, PVC, PET.
<b>Label width:</b>	min. 20mm - max. 100mm.
<b>Label length:</b>	min. 20mm – max. 150mm.
<b>Label thickness:</b>	0,045mm - 0,85mm (50µ-800µ).
<b>Label weight:</b>	up to 300g/m.
<b>Performance:</b>	up to 120 labels/minute*.
<b>Options:</b>	printer table stand (Art. no. CS-1000-STAND).
<b>Dimensions (L x W x H):</b>	651mm x 270mm x 437mm (incl. printer and legs) 183mm x 238mm x 340mm (excl. printer and legs)
<b>Weight:</b>	cca. 7Kg excl. printer, cca. 20Kg incl. Printer

) \*: the system speed depends on variables such as label size, the type and source of the data processed

## 2. Basic Safety Precautions

### 2.1 Coverage

Safety rules and instructions either written or referred to in this manual apply to the installation and the usage of the CS1000-ZX Cutter Stacker. They are complementary to the safety instructions published in Godex printer user's and service manuals, and do not replace those. Therefore, personnel working with the CS1000-ZX must also be (made) familiar with the safety instructions in the applicable Godex printer manuals.

### 2.2 Following these manual's safety instruction

A thorough knowledge of basic safety instructions and safety regulations is an essential prerequisite for using this device in accordance with safety requirements, whilst ensuring its fault-free operation. This operating manual, and in particular the safety instructions contained herein, must be adhered to by any personnel using the device. All relevant standards and regulations pertaining to the prevention of accidents and injuries relevant to the device installation site must also be adhered to.

### 2.3 Possible device handling risks

The device was manufactured in accordance with relevant technical requirements and internationally recognised safety and technical standards. However, situations might still arise during the use of the device that could pose a risk to the health and/or lives of operators and/or third parties, or cause damage to the device and/or other property. The devices contain sharp blades moving with great force and the operator should always ensure no objects other than the label material which is intended to be cut can get in the path of the blades. Working on the electrical components under improper conditions and/or by untrained personnel may cause electrical shock. If used without the printer stand CS-1000-STAND special attention needs to be given to a safe placement near the edge of a stable surface (tilting risk!)

The device may only be used:

- In accordance with the purpose for which it was manufactured (cutting label materials specified in this manual).
- If it is free of any defects in terms of safety and technical requirements.

Any defects that could potentially compromise safety must be rectified immediately.

### 2.4 Environmental conditions

- Operation ambient temperature within the range of 5 °C to 40 °C (41 °F to 104 °F)
- Storage and transport temperature: -20 °C to 55 °C (-4 °F to 131 °F); the device can withstand temperatures of up to 64 °C (149 °F) for a period of up to 24 hours
- Operation ambient non-condensing relative air humidity within the range of 20% to 85% RH
- Storage ambient non-condensing relative air humidity within the range of 20% to 85% RH

## 2.5 Safety rules and instructions

The device contains moving parts that can pose a risk to the operator unless the safety rules are adhered to.

In order to prevent a potential injury, read the following safety rules carefully:

- The device may only be operated by properly trained and authorized personnel.
- The knife cover may only be removed when the device is either not mounted on a printer, or the printer is switched off and disconnected from any power source, as otherwise the device might begin to move unexpectedly.
- Labels that get stuck in or to any part of the cutter stacker or printer may only be removed with the printer switched off and disconnected from any electrical power supply.
- Print material may only be placed in the device whilst the printer is switched off.
- The CS1000-ZX may only be used whilst mounted on either one of the GoDEX ZX1000i printer models. Any other usage of the device is at the sole risk of the user and will void the guarantee.
- When working with the device the operator must adhere to all relevant generally binding safety regulations as specified in the labour code of his/her country and in other legal safety regulations that may apply.
- The device's operator must perform a visual inspection of the device regularly.
- Should there be a discovery of any defect and/or damage that might compromise operating safety and/or the operation of the printer that cannot be rectified on the spot, the device must not be brought into operation / must be switched off immediately, and the defect must be reported to the device's keeper and other relevant persons.
- The legibility of safety signs, symbols and notices on the device must be maintained at all times. In the event of damage and/or illegibility, any such signs must be restored by the device's keeper to their original condition.
- Never connect the device to a source of electric power if any of the protective parts (electric component covers, safety labelling and/or safety elements of the device) have been removed and/or damaged.
- Never modify the mechanical design and/or electrical circuitry of the device in any way.
- Never perform any maintenance tasks before the device has been secured in its off state and the device has been disconnected from the main power.
- Maintenance must be carried out by properly trained and authorized personnel. Failure to do so could result in device failure or injury and may breach health and safety laws.

## 2.6 Applied harmonized standards

- The CS1000-ZX meets the harmonised standards **EN 60439-3**, applicable to low-voltage switch gear and **EN ISO 12100** regarding the safety of machinery as well as **EN 55022:2010**, **EN 55024:2010**, **EN 61000-3-2:2006**, and **EN-61000-3-3: 2008**. All non-live conductive parts are mutually conductively connected and are further connected to the protective earth conductor of the printer's power supply.

## 3. Box Contents and Overview

### 3.1 Unpacking

You have received two boxes (unless you already had the printer on stock). One box contains the CS1000-ZX Cutter Stacker, the other the ZX1000i printer in either 203dpi, 300dpi or 600dpi. The printer comes equipped with factory option ZX-TEXTILE-MOD. Please check whether all content has arrived undamaged:

Picture 1: Cutter Stacker

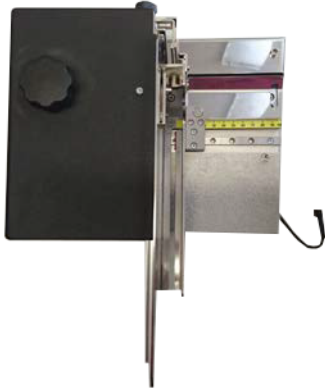

Picture 2: 4 tables



Picture 3: ZX1000i printer front side



Picture 3: printer back side detail



Picture 4: printer legs (optional)



### 3.2 Differences in the printer configuration

There are a few physical differences between standard ZX1000i printers and the ones that come with the ZX-TEXTILE-MOD kit installed. The two USB hosts have been moved to the backside and an easy removable lower left cover has been put in place. Behind this cover you will find the connector and mounting plate for the cutter stacker. However, the printer can still be used like any standard ZX series printer without Cutter Stacker! Only the internal rewinder cannot be used in a printer which has the zx-textile-mod installed. We recommend to leave the cover underneath the display mounted as long as you do not use a Cutter Stacker, to avoid unwanted contact with moving printer parts.

### 3.3 Overview & Process Description

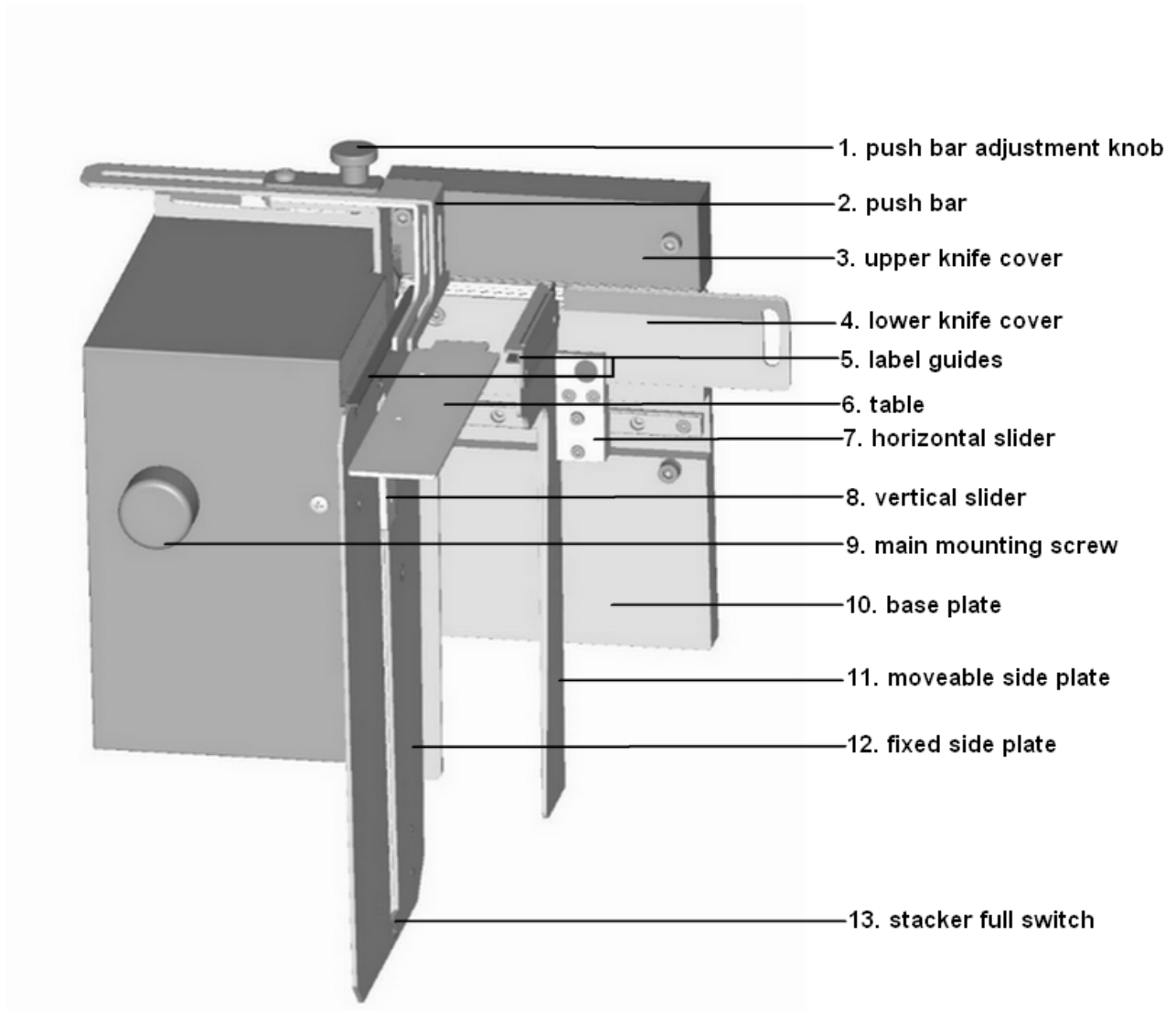

Whilst the label is being printed the printer platen roller forwards it through the cutter and into the label guides (5). The moveable upper blade, hidden behind the upper knife cover (3), will move down as soon as the printing has been completed and thus cut the label. The push bar (2) will move down simultaneously, pushing down the pile of labels which appears on the table (6). The right table width should be used and the vertical magnetic slider (8) underneath the table must be placed in uppermost position when the table is empty. The width of the push bar needs to be adjusted to the label width with knob (1), but the bar should never touch the label guides (5) when moving down! The lower knife cover (4) will move automatically with side plate (11) when adjusting the device to different label widths. Upon reaching its lowest position, the table will activate the "stacker full" switch (13) and the printer will be brought into "PAUSE" status. After emptying the stacker and placing the table (6) back in its upper position, the printer "PAUSE" key is selected to restart the process.

### 3.4 Dimensions

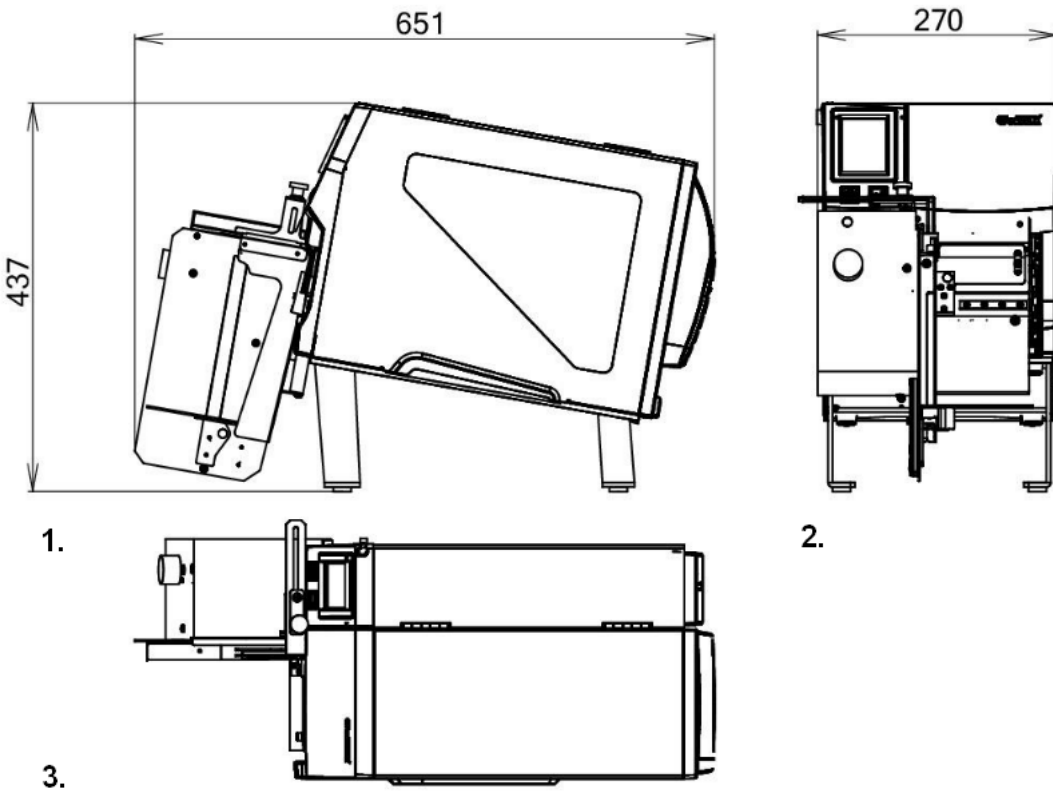

#### **SIZES IN MM**

- 1. SIDE VIEW INCL. PRINTER
- 2. FRONT VIEW INCL. PRINTER
- 3. TOP VIEW INCL. PRINTER
- 4. FRONT VIEW
- 5. SIDE VIEW
- 6. TOP VIEW

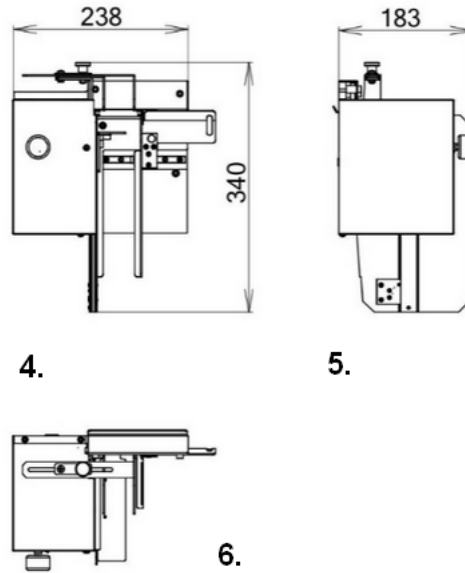



## 4. Mounting the cutter stacker on the printer

Mounting the cutter stacker on the printer is extremely easy. Just follow the steps described in this paragraph. Make sure the printer is off and disconnected from the power network before mounting the cutter stacker. Either place the front end of the printer on the edge of a stable surface or first mount the optional stand as described in § 5.0. The bottom end of the cutter stacker sits deeper than the printer bottom plate.

Step 1: Remove the cover on picture 1.

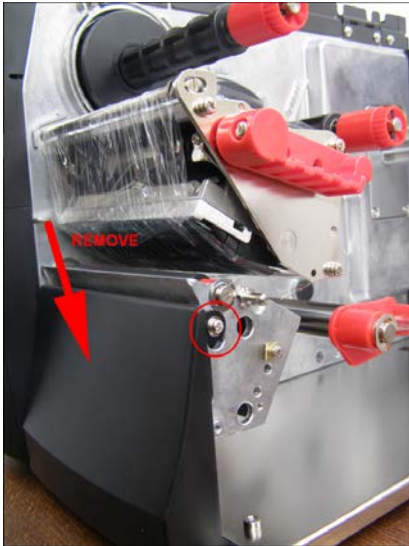

Pic. 1

Step 2: Remove the cover on pictures 2 & 3.



Pic. 2



Pic. 3

Step 3: Take a good look at the mounting panel on the printer (picture 4) and the back side of the Cutter Stacker (picture 5). Notch **A1** must be placed onto pin **A**, plug **B1** inserted into socket **B** and notch **C1** fitted onto pin **C**.



Pic. 4

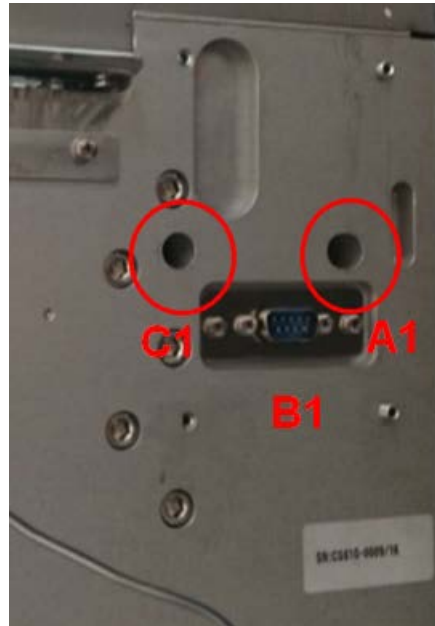

Pic. 5

Step 4: mount the Cutter Stacker on the printer as is shown on pictures 6 – 9.



Pic. 6. Keep the Cutter Stacker firmly.

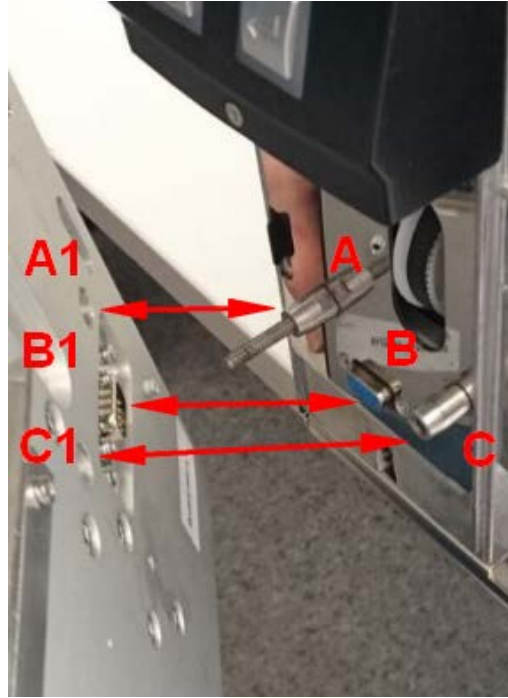

Pic. 7. Place it in the right position.



Pic. 8. Support the Cutter Stacker with one hand and tighten the screw with your free hand.

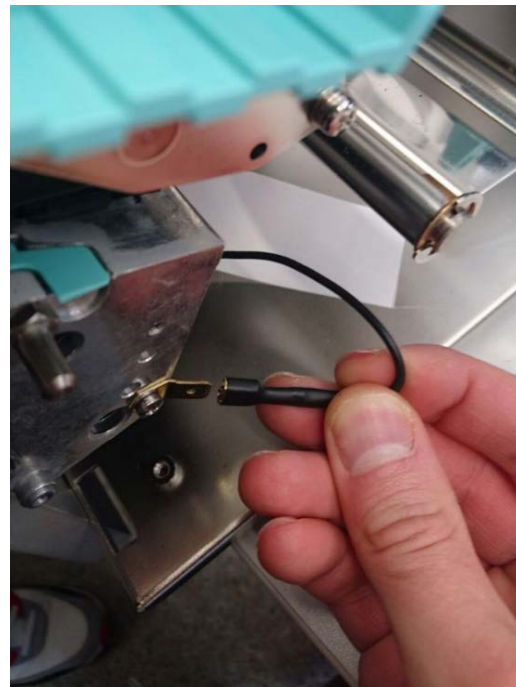

Pic. 9. Connect the static electricity deviation cable to the TPH bracket.

## 5.0 Installing the printer stand (optional)

Using the printer stand CS-1000-STAND is not mandatory but inevitable if you wish to place the unit somewhere else than on the edge of a desk or table. With the legs installed you can place the solution anywhere you want. Still more relevant may be the safety factor. Mounted on the stand the risk of tilting has been eliminated. See here how to install the legs:

Step 1: lay the printer on its side and remove the original feet (A) as shown on picture 2. You will use the original screws (B) to mount the CS-1000-STAND legs.

Step 2: place the lower legs on the back end of the printer, the higher legs on the front end, insert the original screws B and tighten them firmly as shown on picture 3.



Pic. 1. Back and front legs CS-1000-STAND

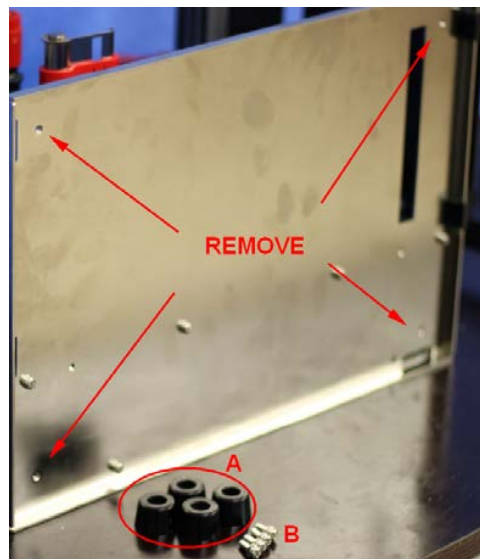

Pic. 2. Removal of original feet

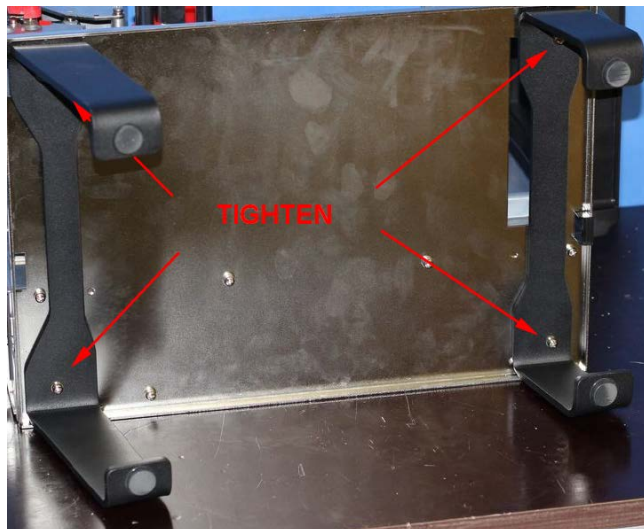

Pic. 3. Legs installed



## 6.0 Operating the Cutter Stacker

### 6.1 Media loading

Picture 1: use thermal transfer ribbons (A) that suit the media you print on. We recommend GoDEX ribbons for extended TPH life cycles and perfect printouts. See the printer manual for instructions, tips and tricks. Load media as is shown by point B.

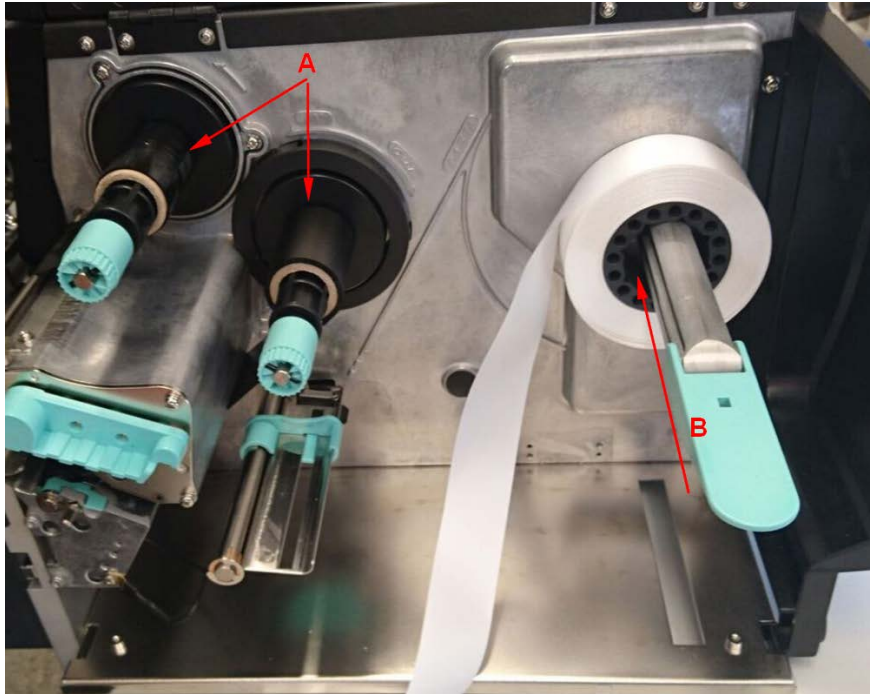

Picture 2: close the label roll holder (A), lead the material underneath the label guide bracket (B) with the printable side up, move the label guide (C) inside until it slightly touches the media, lead the material through the label sensor bar (D) and underneath the printhead into the cutter (E).

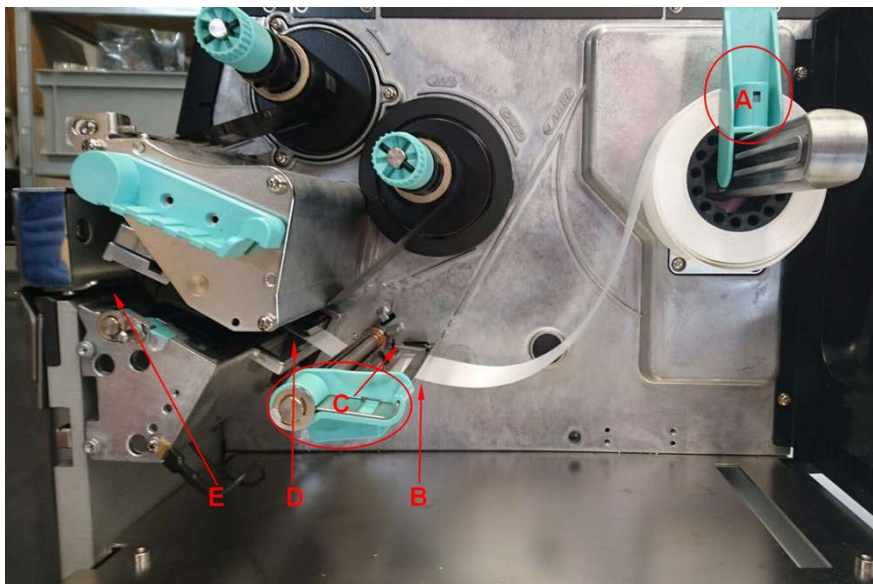

## 6.2 Stacker settings and adjustments

The cutter stacker must be adjusted to the label width and be brought in a correct starting position. The following pictures show how to do this step by step.

Step 1: lead the label material into label guide A as shown on picture 1.

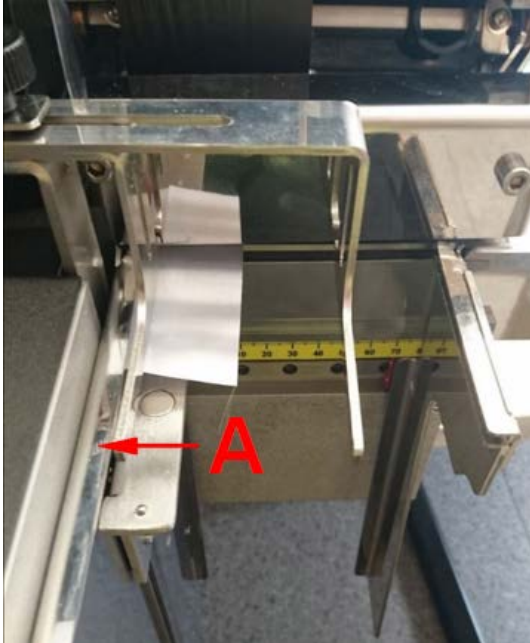

Pic. 1

Step 2: select a table which is just a little narrower than the label material is. The widths most commonly used are included in the initial Cutter Stacker delivery. See picture 2. Other sizes are available on request.



Pic. 2

Step 3: place the table A on bracket B as shown on picture 3. The narrow end towards the printer. Then slide the table up to its uppermost position, visible on picture 4.

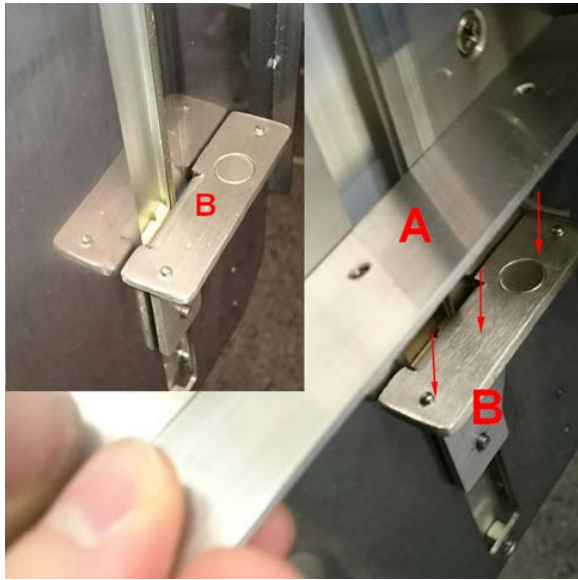

Pic. 3

Step 4: slide the moveable label guide towards the fixed one and make sure the label is inside both of them with a bit of horizontal play on both sides (C on picture 4). Best is to start with more space than is necessary and tune the distance between the guides whilst the device is running. Placing the guides too close to each other might block the label path.

Step 5: check the space between the table and the side plates (A on picture 4). Optimal is 1-2mm, on both sides. Too much space may result in labels falling through. The wider the label, the more tolerance is allowed.

Step 6: make sure there is some horizontal space (B on pictures 4 and 5) between the label guides (1) and the push bars (2). The closer the bars are to the label guides, the better, but never let them hit the guides as that might damage the device! You can slide the bars into correct position after loosening knob D on picture 5. Tighten knob D properly after an adjustment has been made.

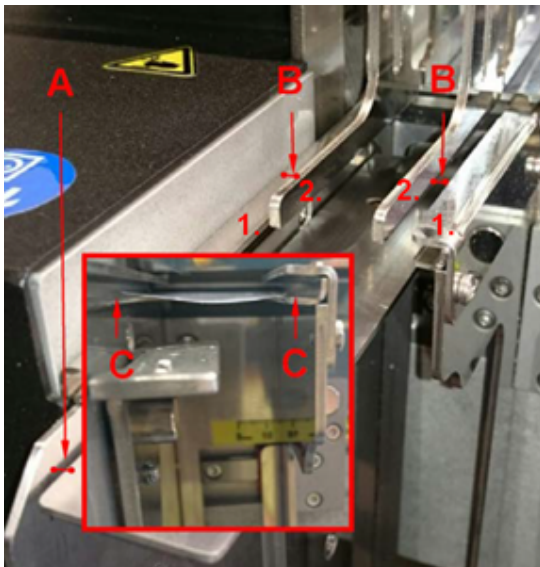

Pic. 4



Pic. 5

## 6.3 Cut line adjustment

The CS1000-ZX has an adjustable cut line, which is a quite unique feature. In the unlikely case materials are not cut straight (not cut under an angle of 90°), it is possible to change the alignment between printer and the Cutter Stacker unit. In virtually all cases this will result in a perfectly straight cut. A general guarantee cannot be given though as there might exist materials which, due to their characteristics, are not suitable for mechanical cutting at all. Picture 1 on this page shows how to re-align the printer and cutter stacker and thus adjust the cut line.

By turning any of the worm screws (A) clockwise or counter-clockwise you decrease, respectively increase the space between the Cutter Stacker and the printer on that spot (red arrows). As a result, also the far end of the cutter will move either closer towards the printer or further away (blue arrows). This way the exact angle can be set.

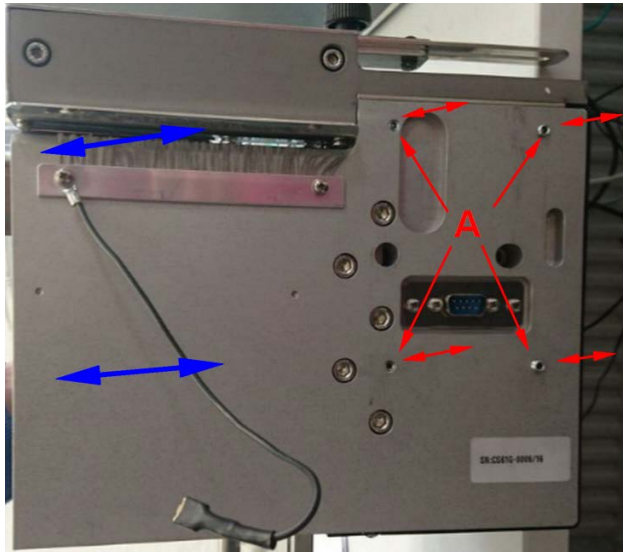

Pic. 1.

## 6.4 Firmware

We recommend to use firmware version V2.Y06 or later.

## 6.5 Printer setup

Make sure you switch on the cutter option in the printer menu and set the stop position at 38mm when using the cutter stacker and printing on continuous materials. Tune to the label and gap size when working with gap labels. Switch on smart backfeed. For further instructions see the printer documentation.

## 6.6 Label creation

You can use our free but powerful GoLabel software which comes with all printers and is downloadable from our website [www.godexintl.com](http://www.godexintl.com) or use Bartender or another major label software which supports GoDEX printers. Printing over a driver is possible as well of course. Always make sure you set the right parameters and enter the right values for working with a cutter / Cutter Stacker. For details please see the label software of your choice and the printer documentation.

## 6.7 Maintenance

The CS1000-ZX cutter stacker is virtually maintenance free and we guarantee a blade life cycle of at least 1 million cuts. This number of cuts is also the recommended interval between inspections by an authorised dealer. This recommendation does neither undo the mandatory visual inspections by the operator mentioned in paragraph 2.5, nor the obligation to timely report any damage or excessive wear. Not doing so might void the warranty.

## 7. Contact and support

Contact either your dealer or one of the GoDEX offices below in case you need any additional information or support. Please base your choice on the region where you are located.

### GoDEX International (Headquarters)

13F, No.168, Jian-Kang Road, Zhonghe Dist,  
New Taipei City, 235 Taiwan  
Telephone: +886 2 2225 8580  
Fax: +886 2 2225 8480  
Contact us: [infoGT@godexintl.com](mailto:infoGT@godexintl.com)  
Technical support: [techGT@godexintl.com](mailto:techGT@godexintl.com)  
Website: [www.godexintl.com/](http://www.godexintl.com/)

### GoDEX Europe GmbH

Arnhäuschen 36, D-42929 Wermelskirchen, Germany  
Telephone: +49 2193 53396 0  
Fax: +49 2193 53396 69  
Contact us: [infoGE@godexintl.com](mailto:infoGE@godexintl.com)  
Technical support: [technikGE@godexintl.com](mailto:technikGE@godexintl.com)  
Website: [www.godexintl.com/de](http://www.godexintl.com/de)

### GoDEX China

3F, No.303 Jiang Chang 3 Road Shanghai, China  
Telephone: +86 21 5665 1313  
Fax: +86 21 5665 7455  
Contact us: [shanghai@godexintl.com](mailto:shanghai@godexintl.com)  
Technical support: [support@godexintl.com](mailto:support@godexintl.com)  
Website: [www.godexintl.com/cn](http://www.godexintl.com/cn)

### GoDEX Americas

4023 Camino Ranchero Rd., Ste A  
Camarillo, CA 93012, USA  
Telephone: +1 805 987 5100  
Fax: +1 805 987 5115  
Contact us: [infoGA@godexintl.com](mailto:infoGA@godexintl.com)  
Technical support: [techsupportGA@godexintl.com](mailto:techsupportGA@godexintl.com)  
Website: [www.godexintl.com/us](http://www.godexintl.com/us)